

**B.Sc. DEGREE EXAMINATION, NOVEMBER 2010****Interior Design****AUTO CAD—I (PRACTICAL)**

Time : 3 Hours

Maximum : 60 Marks

**Section - A**

(5 × 2 = 10)

Answer **all** questions.

1. (a) How do you rotate an object ?

(Or)

- (b) How do you place objects in a circular pattern ?

2. (a) How do you divide one entity into two ?

(Or)

(b) Write the steps to trim the corners.

3. (a) How do you hatch a closed entity ?

*(Or)*

(b) When do you use a match properties ?

4. (a) Which command do you use to draw a smooth curve ?

*(Or)*

(b) What are the different dimension commands ?

5. (a) How do you fill an entity ?

(Or)

(b) How do you change the name of a layer ?

**Section - B**

(5 × 10 = 50)

Answer **all** the questions.

6. (a) Write the steps to create :

(i) New file (ii) Open

(iii) Save (iv) Close

(iv) Exit

(Or)

(b) Write steps in the given commands :

(i) Move      (ii) Copy

(iii) Offset      (iv) Mirror

(v) Array.

7. (a) Write the steps for the following commands :

(i) Break      (ii) Trim

(iii) Extend      (iv) Stretch.

*(Or)*

(b) Write the steps for the following commands :

(i) Undo      (ii) Redo

(iii) Donut      (iv) Solid

8. (a) How do you know which line types are available, also how do you change line types ?

(Or)

(b) How do you hatch (i) in a crowd (ii) outside an entity (iii) inside an entity ?

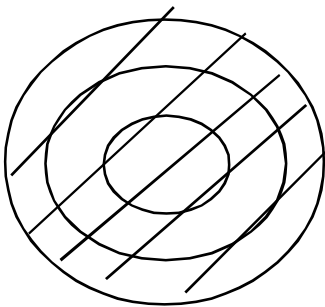

Entities to be hatched

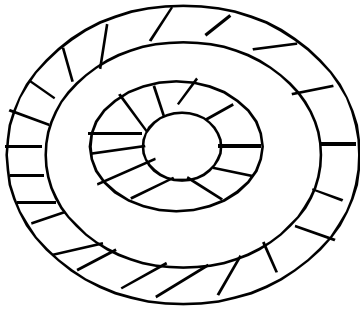

Hatching alternate entities

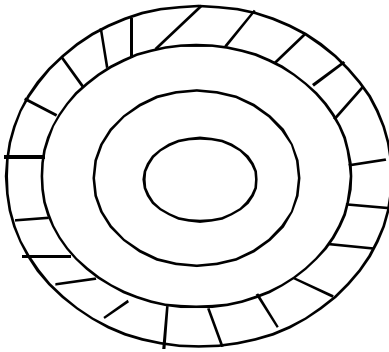

Hatching outside entity

9. (a) How will you find the area of a regular object and an irregular curved surface ?

*(Or)*

- (b) Explain the different types of dimensions with neat sketches.

10. (a) Why do we use extrude command, also write the steps involved in it ?

*(Or)*

- (b) Write a short note about Autocad design centre .

\_\_\_\_\_ \*\*\* \_\_\_\_\_

**B.Sc. DEGREE EXAMINATION, NOVEMBER 2010**

**Interior Design / Fashion Design**

**FRENCH—I**

Time : 3 Hours

Maximum : 60 Marks

**Section - A**

(5 × 2 = 10)

I. Répondez aux question suivantes :

1. Traduisez en français :

(a) Good morning, ladies and gentlemen.

(b) Good afternoon, madam.

(Ou)

(c) I am a professor.

(d) His name is Philippe.



2. Traduisez en anglais :

(a) Vous êtes canadien ?

(b) Aurevoir, madame.

*(Ou)*

(c) Vous êtes chanteur ?

(d) Qu'est-ce que vous faites ?

3. Écrivez les nombres :

(a) sept

(b) vingt

*(Ou)*

(c) dix

(d) onze

4. Écrivez les pluriel des noms :

(a) tableau

(b) cahier

(*Ou*)

(c) jardin

(d) oiseau

5. Complétez avec 1' article défini :

(a) ——— appareil.

(b) ——— arbres.

(*Ou*)

(c) ——— fille.

(d) ——— enfant.

II. 6. Répondez aux questions suivantes :

(a) Comment s'appelle votre père ? Quel âge a-t-il ?

(b) Présentez votre voisin ?

*(Ou)*

(c) Présentez votre mère.

(d) Présentez votre soeur.

7. (a) Écrivez les nombres en lettres :

(i) 21 à 25.

(ii) 71 à 75

*(Ou)*

(b) Donnez le féminin des noms suivants :

(i) avocat

(ii) élève

(iii) ami

(iv) père

(v) époux

(vi) cousin

(vii) employé

(viii) neveu

(ix) étudiant.

(x) frère.

8. (a) Donnez les nationalités des pays suivants :

(i) Allemagne.

(ii) Afrique.

(iii) Amérique.

(iv) Canada.

(v) Chine.

(vi) Japon.

(vii) Bretagne.

(viii) France.

(ix) Italie.

(x) Inde

*(Ou)*

(b) Donnez le féminin des adjectifs suivants :

(i) long.

(ii) intelligent.

(iii) petit.

(iv) vieil.

(v) ancien.

(vi) brun.

(vii) heureux.

(viii) joli.

(ix) blanc

(x) jaune.

9. Conjuguez les verbes suivants :

(a) aimer

(b) aller

*(Ou)*

(c) être

(d) parler

10. (a) Écrivez les mois de l'année.

*(Ou)*

(b) Les vacances scolaires dans votre pays et en France. Comparez.

————— \*\*\* —————

**B.Sc. DEGREE EXAMINATION, NOVEMBER 2010**

**Fashion Design/Interior Design**

**ENGLISH—I**

Time : 3 Hours

Maximum : 60 Marks

**Section - A**

(5 × 2 = 10)

Answer **all** the questions choosing **either** (a) **or** (b)..

1. (a) Give the feminine form for the following nouns :

(i) Jew            (ii) Hero

(iii) Sultan      (iv) Shepherd

(Or)



(b) Find out the nouns that are used as adjectives.

(i) I met a little cottage girl.

(ii) He is always playing computer game.

2. (a) Fill in the blanks with articles :

(i) Twelve inches make ————— foot.

(ii) A bird in ————— hands is worth two in  
————— bush.

(iii) ————— Daniel come to judgement.

(Or)

(b) Fill in the blanks with appropriate pronoun.

(i) \_\_\_\_\_ book is mine.

(ii) He \_\_\_\_\_ said so.

(iii) The horse fell and broke \_\_\_\_\_ leg.

(iv) I met Hari, \_\_\_\_\_ had just returned.

3. (a) Put in the suitable forms of verbs :

(i) I \_\_\_\_\_ English since first standard  
(study).

(ii) The Principal \_\_\_\_\_ to speak to you (want).

(iii) I \_\_\_\_\_ a ticket tomorrow (get).

(iv) I \_\_\_\_\_ a new house next year (go).

*(Or)*

(b) Fill in the blanks with appropriate modals.

(i) I \_\_\_\_\_ swim across the river when I was young.

(ii) You \_\_\_\_\_ go, now.

(iii) You \_\_\_\_\_ improve your spelling.

(iv) He \_\_\_\_\_ not take such a step.

4. (a) Fill in the blanks with the gerunds given in the bracket

(giving, receiving, playing, walking)

(i) He is fond of \_\_\_\_\_ cricket.

(ii) \_\_\_\_\_ is a good exercise.

(iii) \_\_\_\_\_ is better than \_\_\_\_\_.

(Or)

(b) Pick out the participle in each of the following sentences. Tell whether it is a present or past participle.

(i) Being occupied with important matters, he had no leisure to see us.

(ii) Seeing the sunshine, I threw open the window.

5. (a) Fill in the blanks with suitable prepositions.

(i) Radha sat ——— arm chair.

(ii) He married ——— money.

(iii) I saw him ——— the baker's.

(iv) He stayed ——— Mumbai for 5 years.

(Or)

(b) Use apt conjunctions to fill up the blanks :

(i) ——— he was sleeping, an enemy sound tares.

(ii) I am so tired ——— I cannot go on.

(iii) ——— she is poor, she is honest.

(iv) Many things have happened ——— I left school.

**Section - B**

(5 × 10 = 50)

Answer **all** the following questions  
choosing **either** (a) **or** (b)..

6. (a) Write a detailed note on the 'kinds of nouns' and 'gender'.

*(Or)*

- (b) Change the degrees of comparisons without changing the meaning.

(i) Tennyson is not the greatest of all poets.

(ii) Ooty is as healthy as any resort in India.

- (iii) You do not know him better, than I do.
  
- (iv) The tiger is the most ferocious of all animals.
  
- (v) A wise enemy is better than a foolish friend.
  
- (vi) Shakespeare is greater than any other English dramatist.
  
- (vii) No other planet is so big as Jupiter.
  
- (viii) Australia is the largest island in the world.
  
- (ix) Open rebuke is better than secret love.
  
- (x) The pen is mightier than the sword.



7. (a) Write a note on 'Articles'.

(Or)

(b) Write the correct form of pronouns in the following blanks :

(i) \_\_\_\_\_ and you are good friends (I, You).

(ii) \_\_\_\_\_ is ten O' clock (Its, It)

(iii) Rajesh is taller than \_\_\_\_\_ (me, I)

(iv) Rama is as old as \_\_\_\_\_ (I, me)

(v) I \_\_\_\_\_ killed the man (myself, herself)

(vi) That pen is ————— (your's yours)

(vii) ————— of them were Gurkhas (one, many)

(viii) They all gave evidence against ———  
(each other, one another)

(ix) I found the result ————— was very tough  
(which, where)

(x) Most people get ————— they deserve  
(what, which)

8. (a) Write an essay on 'Tenses' with suitable examples.

(Or)

(b) Find out the error in the following and make necessary corrections.

(i) Ten kilometers are not a long distance by car.

(ii) My Mathematics is poor.

(iii) My husband as well as his cousins have agreed to this.

(iv) There is lots of stars in the sky.

(v) Every school and college have library.

(vi) The surface of these roads need tarring.

(vii) Either he or his friends is sure to come.

(viii) Three roses are a movie.

(ix) He is having a car.

(x) She were right.

9. (a) Write an essay on 'Gerund'.

*(Or)*

(b) Combine the following pairs of sentences by making use of participles.

(i) The porter opened the gate. We entered.

- (ii) We met a man. He was carrying a log of wood.
- (iii) He seized his stick. He rushed to the door.
- (iv) A crow stole a piece of cheese. She flew to her nest to enjoy the tasty meal.
- (v) A passenger alighted from the train. He fell over a bag on the platform.
- (vi) My sister was charmed with the silk, she bought ten yards.
- (vii) He had resolved on a certain course. He acted with vigour.

(viii) The letter was badly written. I had great difficulty in making out its contents.

(ix) A hungry fox saw some bunches of grapes. They were hanging from a vine..

(x) The stable door was open. The horse was stolen.

10. (a) Distinguish the prepositions from adverbs in the following sentences :

(i) Come down.

(ii) We sailed down the river.

(iii) The man walked round the house.

(iv) We cannot live without water.

(v) The storm is roaring without.

(vi) He is in the room.

(vii) We all went in.

(viii) The man turned round.

(ix) The carriage moved on.

(x) The soldiers passed by.

*(Or)*

(b) Fill in the blanks with conjunctions :

- (i) ————— somewhat pompous, he was an entertaining companion.
- (ii) The heavens declare the glory of God,  
————— the firmament showeth this handi-work.
- (iii) It is a great loss to man ——— he cannot laugh.
- (iv) I have imposed upon myself ————— I have been guilty of no other imposition.
- (v) ————— I feel any doubt I enquire.



- (vi) I shall not go ———— you do.
- (vii) ———— he found fault, he also praised.
- (viii) Fit words are better ———— fine ones.
- (ix) ———— I am in a serious humour, I very often walk by myself in Westminster Abbey.
- (x) ———— you are upon Earth enjoy the good things that are here ———— be not melancholy.

————— \*\*\* —————

**B.Sc. DEGREE EXAMINATION, NOVEMBER 2010**

**Interior Design**

**HISTORY OF ART AND ARCHITECTURE**

Time : 3 Hours

Maximum : 60 Marks

**Section - A**

(5 × 2 = 10)

Answer **all** questions.

1. (a) Compare Old stone age and new stone age developments of Shelter.

*(Or)*

- (b) Sketch a pyramid of Egyptian architecture.

2. (a) State any three architectural characters in Greek architecture.

*(Or)*

(b) State Ionic order of Greek architecture.

3. (a) State any three architectural characters of Hindu architecture.

*(Or)*

(b) Outline the characters of Gupta and Chalukyan period Shrines.

4. (a) Shore temple at Mahabalipuram—Explain.

*(Or)*

(b) Mention the characteristic features of Dravidian architecture.

5. (a) Write short notes on Indo-Aryan style.

*(Or)*

- (b) Mention any five characteristic features of Lingaraju temple Bhubaneshwar.

**Section - B**

(5 × 10 = 50)

Answer **all** questions.

6. (a) Outline the architectural characters of Egyptian architecture with examples and diagrams.

*(Or)*

- (b) Describe the developments of Shelter related to prehistoric age with diagrams.

7. (a) Explain the three orders of Greek architecture with diagrams.

*(Or)*

- (b) Explain Parthenon, Athens with proper diagrams.

8. (a) Explain the evolution of Hindu temples with neat diagrams.

*(Or)*

- (b) Describe the architectural character of Virupaksha temple at Pattadakal.

9. (a) Describe the characteristic features of Pallava architecture with sketches.

*(Or)*

- (b) Explain the architectural character of Brihadeeswara temple in Tanjore with sketches.

10. (a) Describe the architectural features of Lingaraja temple in Bhubaneshwar.

*(Or)*

- (b) Describe the plan and view of Sun temple Konark with diagrams.

————— \*\*\* —————

**B.Sc. DEGREE EXAMINATION, NOVEMBER 2010**

**Interior Design**

**BASIC PLANNING AND DESIGNING (PRACTICAL)**

Time : 3 Hours

Maximum : 60 Marks

**Section - A**

(5 × 2 = 10)

Answer **all** questions.

1. (a) What is Engineering Drawing ?

*(Or)*

- (b) Write the uses of set square.

2. (a) Write a short note on the types of letters used in engineering.

*(Or)*

(b) Write a short note on single stroke letters.

3. (a) What is Anthropometry ?

(Or)

(b) Discuss good *vs.* bad circulation of space in a living room.

4. (a) What is parallel dimension ?

(Or)

(b) Draw the wooden joints (i) Shiplap (ii) Tongue and Groove.



5. (a) What are the different types of floors used ?

(Or)

(b) Write the uses of Plywood.

**Section - B**

(5 × 10 = 50)

Answer **all** questions.

6. (a) Explain in detail :

(i) T-square. (4)

(ii) Set-square. (4)

(iii) Their uses (2)

(Or)

(b) Explain the types of scales and write its uses.

(6 +4)

7. (a) Neatly write :

- (i) Vertical capital letters (A – Z) (4)
- (ii) Vertical lower case letters (a – z) (3)
- (iii) Numbers (0 to 9) (3)

*(Or)*

(b) Application of various lines used in engineering and architectural design.

(10)

8. (a) Draw a living room size 12'0"×14'0". Provide all the furniture. Draw any one furniture to detail. (Scale ½"×1'0").

(10)

*(Or)*

(b) Draw the plan of a master bedroom of size 12'0"×14'0". Provide all the required furnitures. Draw any one furniture to detail (Scale ½"×1'0").

(10)

9. (a) (i) What is parallel Dimensioning ? (3)

(ii) What is super imposed running dimension ?

(4)

(iii) What is chain dimensioning ? (3)

(Or)

(b) Draw the given wooden joints (Scale 1 : 5)

END JOINTS:

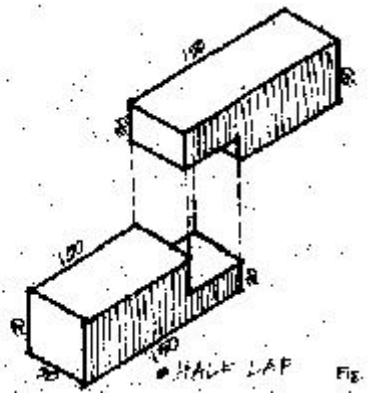
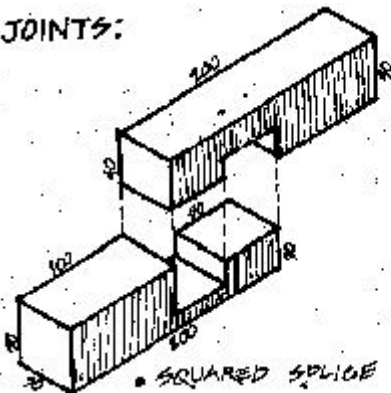

(5)

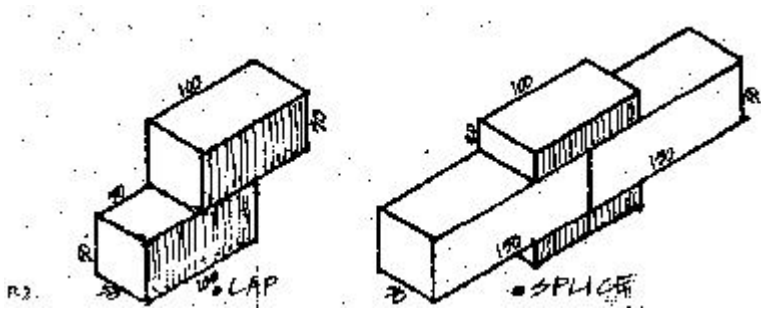

All dimensions in mm.

(5)

10. (a) Discuss the different types of plywood and their related products and uses.

(10)

(Or)

- (b) What are paints, their related products and uses ?

————— \*\*\* —————

**B.Sc. DEGREE EXAMINATION, NOVEMBER 2010**

**Interior Design**

**ELEMENTS OF DESIGN (PRACTICAL)**

Time : 3 Hours

Maximum : 60 Marks

**Section - A**

(5 × 2 = 10)

Answer **all** questions.

1. (a) Name the different elements of design.

*(Or)*

- (b) Sketch 'Rising Sun' with a free hand drawing.

2. (a) Draw any two types of Polygon.

*(Or)*

- (b) Write the practical application of Geometrical drawing.
3. (a) Draw any door of size 3 feet  $\times$  7 feet with a measured scale.

*(Or)*

- (b) Draw a French window of size 6 feet  $\times$  7 feet with a measured scale.
4. (a) Draw the sociography of a bay window.

*(Or)*

(b) Define the term 'Sociography'.

5. (a) Draw the Isometric projection of a Cube.

*(Or)*

(b) Define the term 'Orthographic projection'.

**Section - B**

(5 × 10 = 50)

Answer **all** questions.

6. (a) Draw the different shapes of kitchen with a neat free hand drawing.

*(Or)*

(b) Explain 'Form' and 'Balance' in Interior Design with suitable sketches.

7. (a) Draw any three types of regular polygon.

*(Or)*

(b) Draw the construction of any two geometrical figures.

8. (a) Draw the different types of doors and windows of standard size.

*(Or)*

(b) Draw simple objects like furniture, window grills, cornice and mouldings of standard size.



9. (a) Explain shadows of architectural elements with suitable sketches.

*(Or)*

- (b) Explain the principles and shadows in design with sketches.

10. (a) Explain the term 'Orthographic projection' with suitable sketches.

*(Or)*

- (b) Draw the plan, elevation and section of a room of size 11 feet × 16 feet.

————— \*\*\* —————

**B.Sc. DEGREE EXAMINATION, NOVEMBER 2010****Interior Design****MODERN INTERIORS**

Time : 3 Hours

Maximum : 60 Marks

**Section - A**

(5 × 2 = 10)

Answer **all** the questions.

1. (a) Define Modern interior design.

*(Or)*

- (b) Write the features of Modern interior design.

2. (a) Define Suspended ceiling.

*(Or)*

(b) What are the categories of false ceiling ?

3. (a) What is ergonomic triangle ?

*(Or)*

(b) What do you mean by Modular kitchen ?

4. (a) Name the different types of lighting arrangements.

*(Or)*

(b) Write a short note on variety of lamps and lighting accessories.

5. (a) What do you mean by organisation of office space ?

*(Or)*

- (b) What are the points to be considered while organizing an office space ?

**Section - B**

(5 × 10 = 50)

Answer **all** the questions.

6. (a) Write in detail with neat sketches about the introduction to modern interior design.

*(Or)*

- (b) Write the principles and features of modern interior design with sketches.

7. (a) Explain with neat sketches the categories of false ceiling.

*(Or)*

- (b) Write the drawing method of false ceiling also write the assumptions of false ceiling.

8. (a) With neat sketches explain the ergonomic triangle for modular kitchen.

*(Or)*

- (b) Draw and explain ideal kitchen plan.

9. (a) Discuss in detail the different types of lighting arrangements.

(Or)

(b) Discuss the variety of lamps, lighting accessories and electrical wires.

10. (a) Explain in detail the organisation of office spaces with examples.

(Or)

(b) Explain circular space-plan, elevation, section of an office with suitable examples.

————— \*\*\* —————

**B.Sc. DEGREE EXAMINATION, NOVEMBER 2010****Interior Design****MATERIAL SCIENCE—I**

Time : 3 Hours

Maximum : 60 Marks

**Section - A**

(5 × 2 = 10)

Answer **all** the questions.

1. (a) Define the term 'Ceramics'.

(Or)

- (b) What are the advantages of terra cotta ?

2. (a) What are the ingredients of paints ?

(Or)

(b) What is colour wheel ?

3. (a) Write a note on Bathroom fittings.

*(Or)*

(b) State the different sizes of bathtubs available in the market.

4. (a) Write short notes on partition materials.

*(Or)*

(b) Sketch a common timber partition and label its parts.



5. (a) Write short notes on wall papers used in interiors.

*(Or)*

- (b) Name the different floor coverings in interior design.

**Section - B**

(5 × 10 = 50)

Answer **all** the questions.

6. (a) Explain the different types of common tiles available in the market with suitable diagrams.

*(Or)*

- (b) Explain the different classification of refractory materials.

7. (a) What is a paint ? Explain the different types of paints used in interior designing.

*(Or)*

- (b) Explain theory of colours and colour wheel in interior designing with suitable diagrams.

8. (a) Explain any five bathroom fittings used in interiors with sketches.

*(Or)*

- (b) Draw the plan and sectional elevation of 6 feet × 8 feet bathroom and explain the concept of fittings used in it.

9. (a) Describe any three types of partition materials with suitable diagrams.

(Or)

(b) Explain in detail (i) Hollow clay block partition (ii) Timber partition.

10. (a) Explain any five basic materials used for interiors with sketches.

(Or)

(b) Explain the following :

(i) Curtains and Upholstery.

(ii) Carpets.

(iii) Venetian Blinds.

————— \*\*\* —————

**B.Sc. DEGREE EXAMINATION, NOVEMBER 2010**

**Interior Design**

**CONSTRUCTION TECHNIQUES**

Time : 3 Hours

Maximum : 60 Marks

**Section - A**

(5 × 2 = 10)

Answer **all** the questions.

1. (a) Write short note on vibroflotation.

*(Or)*

- (b) Write explanatory notes on cantilever footing.

2. (a) Define the term Damp-proofing.

*(Or)*

(b) Write short notes on asphalt tanking for basement.

3. (a) Define the term winder.

*(Or)*

(b) Differentiate between Soffit and Scotia.

4. (a) Explain Saddle joint with sketches.

*(Or)*

(b) Define the term Squint quoin.

5. (a) Write short notes o Florentine arch.

*(Or)*

- (b) The Rubble Masonary arch is used for inferior type of work—Discuss.

**Section - B**

(5 × 10 = 50)

Answer **all** the questions.

6. (a) How will you Design the width and depth of shallow foundations ?

*(Or)*

- (b) Give sketches of cross-section of a typical bore-hole.

7. (a) What are the general principles to be observed in all the methods in damp-proofing ?

*(Or)*

- (b) Prepare a list of materials which are commonly used for a damp-proofing course and briefly describe each of them.

8. (a) Draw a neat sketch of a spiral stair and mention its important features.

*(Or)*

- (b) Enumerate the different types of stairs.

9. (a) What are the different types of Ashlar Masonary ?

*(Or)*

- (b) Give a list of types of bonds in brick work.

10. (a) How are arches classified ?

*(Or)*

- (b) Mention the ways of failure of an arch and suggest suitable measures to avoid such failures.

————— \*\*\* —————



**B.Sc. DEGREE EXAMINATION, NOVEMBER 2010**

**Interior Design**

**DESIGN STUDIO—I—(PRACTICAL)**

Time : 3 Hours

Maximum : 60 Marks

**Section - A**

(5 × 2 = 10)

Answer **all** the questions.

1. (a) Define the term 'planning' in interior design.

*(Or)*

- (b) Define the term interior design.

2. (a) Give the general requirements for a residence of two bedroom design.

*(Or)*

(b) Define the term 'Organisation of Space'.

3. (a) Write short notes on 'Material Research Board'.

*(Or)*

(b) Mention the importance of Material Research Board in interior design.

4. (a) State the important points for the design of a living room.

*(Or)*

(b) Write the concept of planning a bedroom design.

5. (a) Write the general requirements for a three bedroom flats.

(Or)

- (b) Residential space designing—Explain.

**Section - B**

(5 × 10 = 50)

Answer **all** questions.

6. (a) Draw the plan and sectional elevation of a living room for a small residence with sketches.

(Or)

- (b) Sketch and explain the concept of isometric projections taking kitchen as example.

7. (a) Explain the concept of interior layout for a typical residence with sketches.

*(Or)*

- (b) Describe the concept of organisation of space for a small residence with sketches.

8. (a) Explain the concept of Material Research Board in interior design.

*(Or)*

- (b) Explain the concept of Material Research Board taking a small office as an example.

9. (a) Draw the plan and sectional elevation of a bedroom of size 10 feet  $\times$  12 feet.

*(Or)*

- (b) Draw the plan and sectional elevation of a kitchen of size 10 feet  $\times$  8 feet.

10. (a) Explain the space planning and design of a three bedroom apartments with sketches.

*(Or)*

- (b) Explain the space planning and design for a Residential house of four bedrooms with neat sketches.

————— \*\*\* —————